



Hook accessories

Big Bag

Index table

	RPS Code	200VBBLIFT2000AR	200VBBLIFT2000ASR	200VBBLIFT2000REM	200VBBLIFT2000IN
Description	Model	SIMPLEX	ASR	REM	SIMPLEX INOX
	Coating	RAL 1028			INOX 304
	Net weight	45 kg	55 kg	142 kg	48 kg
	Security	Hooks with safety latches			
	UNE norm	According norm UNE-EN13155:2004			
	Max. load	2000 kg			
	Losed height	Lost 185 mm	Win 20 mm	Win 175 mm	Lost 115 mm



Implemento SIMPLEX



Tel: (+34) 93 635 61 20 - info@vinca.es - www.vinca.es

Big Bag

SIMPLEX

Ref: 200VBBLIFT2000AR

- **Coating:** Yellow RAL 1028 C3L 80µm
- **Max. load:** 2000kg
- **Net weight:** 45kg
- Hooks with safety latches
- Losed height of 185 mm
- W/ User and maintenance manual
- W/ CE Certificate
- According norm UNE-EN 13155:2004
- **In case of use with chain hoist, verify accurately the possible interference with hoist chainbag.**

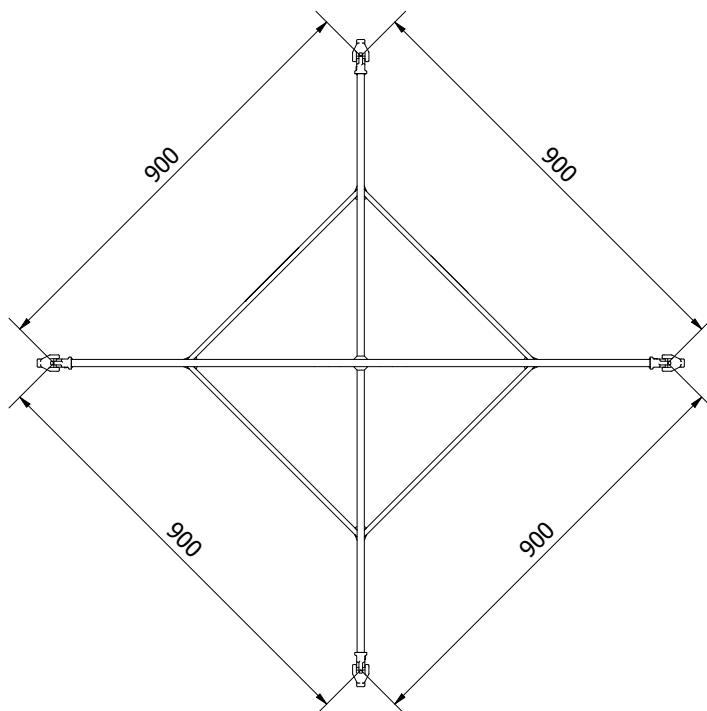
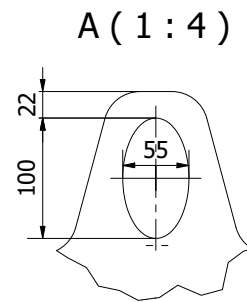
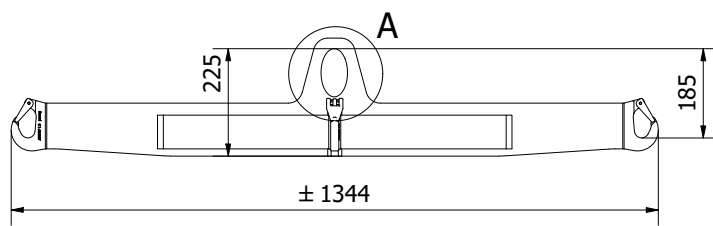

SIMPLEX INOX

Ref: 200VBBLIFT2000IN

- **Coating:** Stainless steel AISI304
- **Max. load:** 2000kg
- **Net weight:** 45kg
- Hooks with safety latches
- Losed height of 115 mm
- W/ User and maintenance manual
- W/ CE Certificate
- According norm UNE-EN 13155:2004
- **In case of use with chain hoist, verify accurately the possible interference with hoist chainbag.**

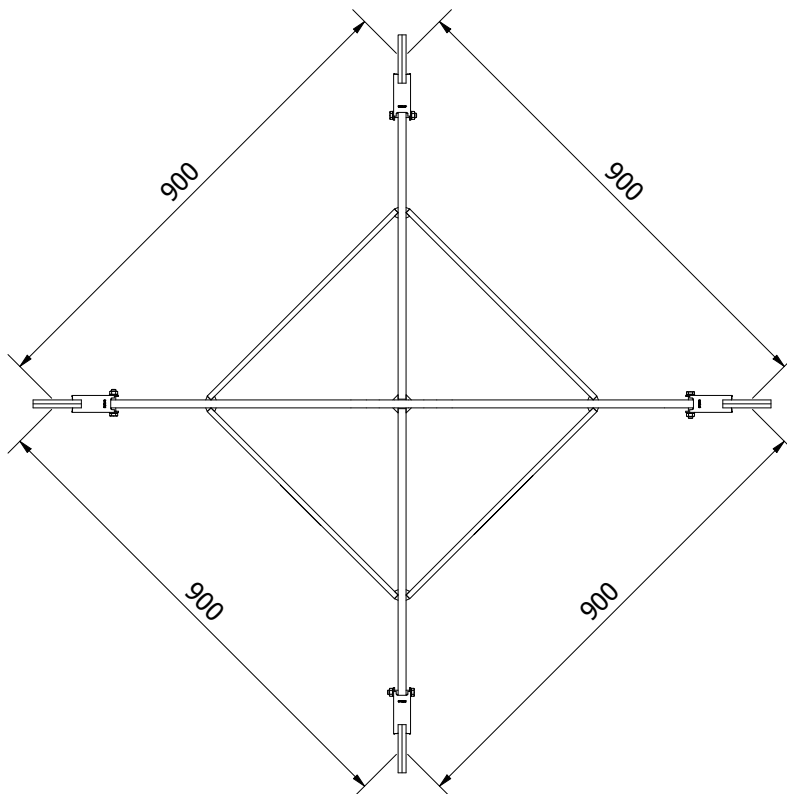
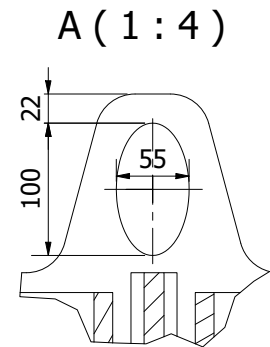
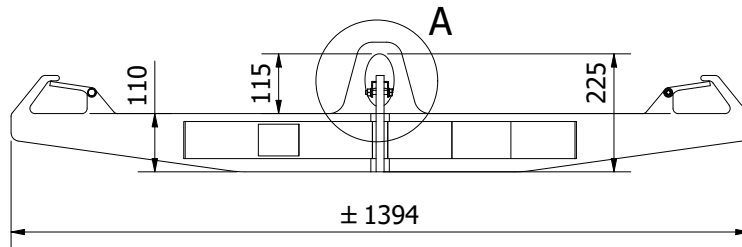

Tel: (+34) 93 635 61 20 - info@vinca.es - www.vinca.es

Big Bag

ASR

Ref: 200VBBLIFT2000ASR

- **Coating:** Yellow RAL 1028 C3L 80µm
- **Max. load:** 2000kg
- **Net weight:** 55kg
- Hooks with safety latches
- Gained height of 20 mm
- W/ User and maintenance manual
- W/ CE Certificate
- According norm UNE-EN 13155:2004
- **In case of use with chain hoist, verify accurately the possible interference with hoist chainbag.**
- **Verify the length of Big Bag lifting loops to avoid interference with the frame.**

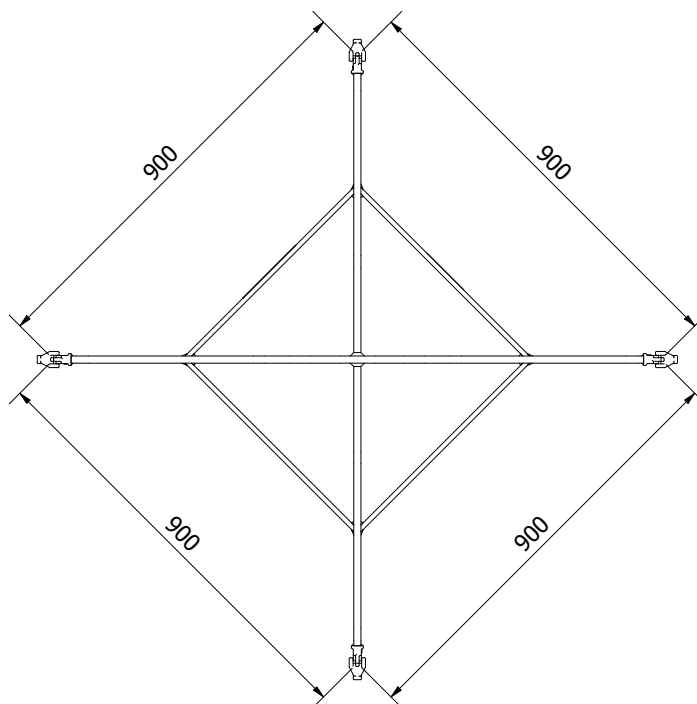
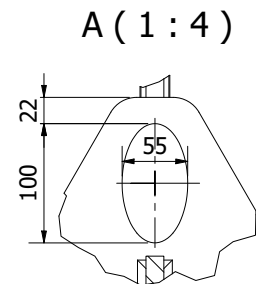
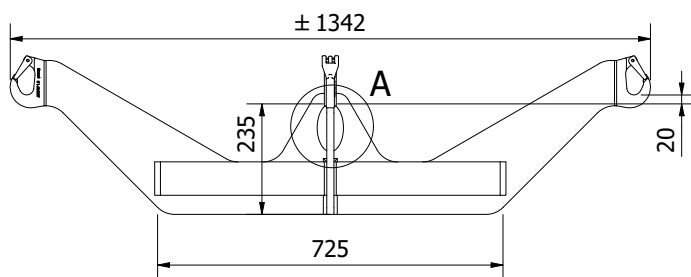

REM

Ref: 200VBBLIFT2000REM

- **Coating:** Yellow RAL 1028 C3L 80µm
- **Max. load:** 2000kg
- **Net weight:** 140kg
- Hooks with safety latches
- Gained height of 175 mm
- W/ User and maintenance manual
- W/ CE Certificate
- According norm UNE-EN 13155:2004
- **In case of use with chain hoist, verify accurately the possible interference with hoist chainbag.**
- **Verify the lenght of Big Bag lifting loops to avoid interference with the frame.**

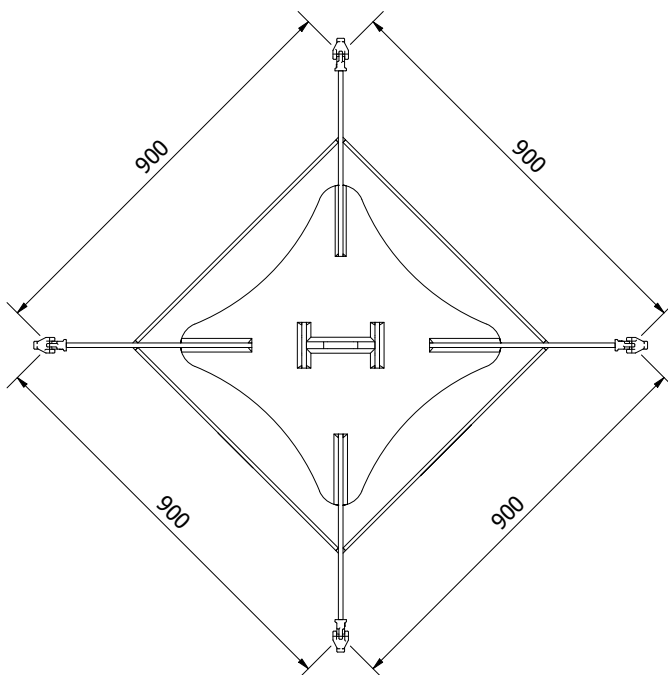
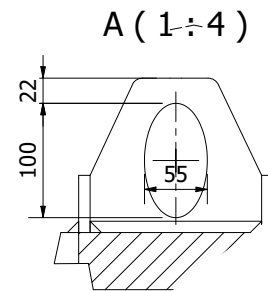
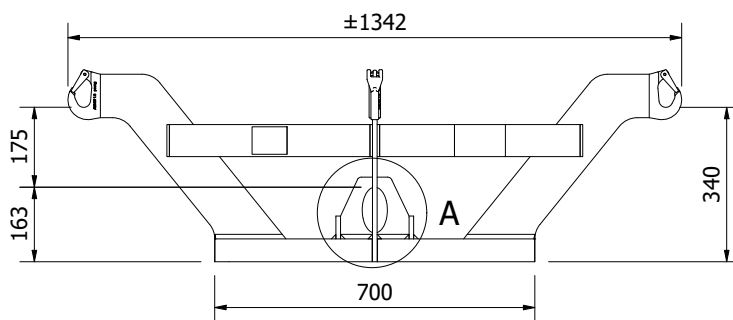

**Recommended model
for superreduced space cases.**

Tel: (+34) 93 635 61 20 - info@vinca.es - www.vinca.es

VINCA products

- Bridges crane and gantry cranes
- Jib cranes
- Hoists and winches
- Scissor Tables and scissor lifts
- Elevators/Lifts for loads (PLT)
- Dock levelers
- Moving Dock levelers (RMC)
- Coats Furniture
- Wheel-lok (Vehicle Immobilizer)
- Safety equipment for docks
- Vacuum lifters VACU-LIFT
- Industrial Manipulators
- Pallet Inverters /Tippers
- Levelers NIVELMATIC
- Tilters inclinador
- Skips
- Industrial fans
- Industrial flexible doors, high speed doors
- Cold storage doors
- Fire doors
- Safety gates DOK-GUARDIAN
- Festoon for mobile equipment
- Lifting appliances
- Industrial Radio Controls
- After Sales Service for above equipment

 ATEX classified equipment as option.



BARCELONA

Tel 93 635 61 20
Fax 93 635 61 30
info@vinca.es

MADRID

Tel: (+34) 616 91 69 82
madrid@vinca.es

C/ Técnica, 39

Pol. Ind. Torre Bovera

08740 Sant Andreu de la Barca

BARCELONA

www.vinca.es



VALENCIA

Tel: (+34) 647 817 537
valencia@vinca.es

GALICIA

Tel: (+34) 648 923 832
galicia@vinca.es