



# Lifting-Appliances

Palets lifter



# Palets Lifter

## TKG vhs

### Crane forks

with adjustable tines, height adjustability and automatic balancing system

These crane forks are equipped with adjustable tines, height adjustability and an automatic balancing system. Crane forks with automatic balancing\* tend to point their tines upward when being transported. This prevents the load from unintentionally slipping off the tines.

The shackle is movable and runs on a track depending on the load. The automatic balancing engages by a pressurized gas spring once the forks are loaded. The load will always be in the center of gravity of the forks, ensuring a safe transport.

- all crane forks comply to the safety specifications from the German trade association
- type-tested 4 to 1 against breakage • maintenance-free
- highly visible safety color
- for the transport of rings or coils, the fork tines are simply pushed together
- easily adjustable tines for all pallet sizes



\*The automatic balancing system requires a minimum load of 20% of the crane fork's working load limit.

### Optionally available

- Chain for load securing

### Technical Data

Model	Article Number	Capacity t	Weight Kg
TKG 1,0 vhs	5340.7531	1,0	140
TKG 1,5 vhs	5340.7532	1,5	165
TKG 2,0 vhs	5340.7533	2,0	220
TKG 3,0 vhs	5340.7534	3,0	280
TKG 5,0 vhs	5340.7535	5,0	380

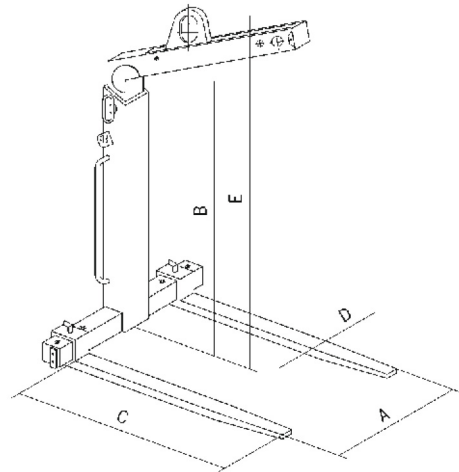

### Dimensions

Model	TKG 1,0 vhs	TKG 1,5 vhs	TKG 2,0 vhs	TKG 3,0 vhs	TKG 5,0 vhs
Adjustment of tines A, mm	350 - 900		400 - 900	450 - 900	500 - 1000
Useable height B, mm	1100 - 1600	1300 - 2000			
Length of tines C, mm	1000				
Section of tines D, mm	100 x 30	100 x 40	120 x 40	120 x 50	150 x 60
Overall height E, mm	1420 - 1920	1650 - 2350	1655 - 2355	1720 - 2420	1710 - 2410

# Palets lifter

## TKG vh

### Crane forks

with adjustable tines, height adjustability and manual balancing system

These crane forks are equipped with adjustable tines and height adjustability. The balancing system engages when the shackle is manually hooked into the appropriate notch.

- all crane forks comply to the safety specifications from the German trade association
- type-tested 4 to 1 against breakage
- maintenance-free
- highly visible safety color
- for the transport of rings or coils, the fork tines are simply pushed together
- easily adjustable tines for all pallet sizes

### Optionally available

- Chain for load securing



### Technical Data

Model	Article Number	Capacity t	Weight Kg
TKG 1,0 vh	5340.7511	1,0	130
TKG 1,5 vh	5340.7512	1,5	150
TKG 2,0 vh	5340.7513	2,0	200
TKG 3,0 vh	5340.7514	3,0	250
TKG 5,0 vh	5340.7515	5,0	370

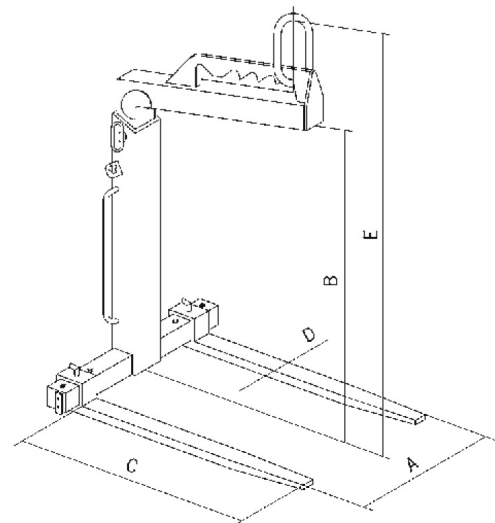

### Dimensions

Model	TKG 1,0 vh	TKG 1,5 vh	TKG 2,0 vh	TKG 3,0 vh	TKG 5,0 vh
Adjustment of tines A, mm	350 - 900		400 - 900	450 - 900	500 - 1000
Useable height B, mm	1100 - 1600	1300 - 2000			
Length of tines C, mm	1000				
Section of tines D, mm	100 x 30	100 x 40	120 x 40	120 x 50	150 x 60
Overall height E, mm	1390 - 1890	1600 - 2300	1640 - 2340	1670 - 2370	1700 - 2400

## VINCA products

- Bridges crane and gantry cranes
- Jib cranes
- Hoists and winches
- Scissor Tables and scissor lifts
- Elevators/Lifts for loads (PLT)
- Dock levelers
- Moving Dock levelers (RMC)
- Coats Furniture
- Wheel-lok (Vehicle Immobilizer)
- Safety equipment for docks
- Vacuum lifters VACU-LIFT
- Industrial Manipulators
- Pallet Inverters /Tippers
- Levelers NIVELMATIC
- Tilters inclinador
- Skips
- Industrial fans
- Industrial flexible doors, high speed doors
- Cold storage doors
- Fire doors
- Safety gates DOK-GUARDIAN
- Festoon for mobile equipment
- Lifting appliances
- Industrial Radio Controls
- After Sales Service for above equipment

⊕ ATEX classified equipment as option.



C/ Técnica, 39  
 Pol. Ind. Torre Bovera  
 08740 St. Andreu de la Barca  
 BARCELONA  
[www.vinca.es](http://www.vinca.es)



### BARCELONA

Tel 93 635 61 20  
 Fax 93 635 61 30  
[info@vinca.es](mailto:info@vinca.es)

### MADRID

Tel: (+34) 616 91 69 82  
[madrid@vinca.es](mailto:madrid@vinca.es)

### VALENCIA

Tel: (+34) 647 817 537  
[valencia@vinca.es](mailto:valencia@vinca.es)

### GALICIA

Tel: (+34) 648 923 832  
[galicia@vinca.es](mailto:galicia@vinca.es)