



VINCA

EQUIPOS INDUSTRIALES



Loading dock safety systems

Coolman 2800 Trailer Fan

75.6-ventilador-coolman_en

CoolMan® 2800 Trailer Fan with Flex Neck LED Dock Light

Increase worker comfort and productivity by controlling temperatures inside a trailer.

Performance

- Fully enclosed 0,375 kW, 230V/50Hz, single-phase, three speed motor: 1020 1/min, 1225 1/min, 1350 1/min
- Save energy by setting variable auto-o timer from 1 up to 180 minutes

Construction

- Yellow polypropylene copolymer housing
- T-style handle for easy vertical or horizontal adjustment
- Mounting bracket and arm swivels to service two loading dock openings
- Optional adjustable mounting bracket allows the unit to move up to 480 mm for ideal positioning in the trailer



Flex Neck LED Dock Light

- 18-watt Flex Neck Style dock light
- Four different settings with visual indicators to clearly identify the current level of lighting allowing users to select the desired level of light output
- CE certified
- Impact-resistant head (no glass)
- Optional Motion Sensing Technology senses when a forklift or person is leaving a trailer and automatically dims the light to 25% output, restoring to full power after a few seconds



Image shown with optional Rite-Lite LED Dock Light

Ventilador Coolman 2800

Specifications

Standard features

- 0,375 kW three speed blower motor
- Power supply: 230V/50Hz 1 Ph., FLA 2.2 A
- Cable 6.1 m with safety plug (Schuko CEE7/7, 250V/16A)
- Auto-on timer for saving energy, variable from 1 up to 180 minutes
- 3 adjustable airflow levels: low = 53.80 m/min, medium = 62.30 m/min, high = 67.95 m/min
- Housing made of yellow polypropylene copolymer (PPC)
- Air inlet & air outlet with protective grid
- T-style handle for simple horizontal or vertical adjustment of the blower
- Swivelable double strut arm to service two loading dock openings



Ventilador Coolman 2800

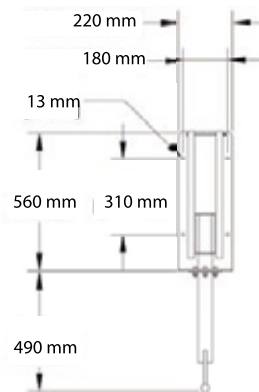
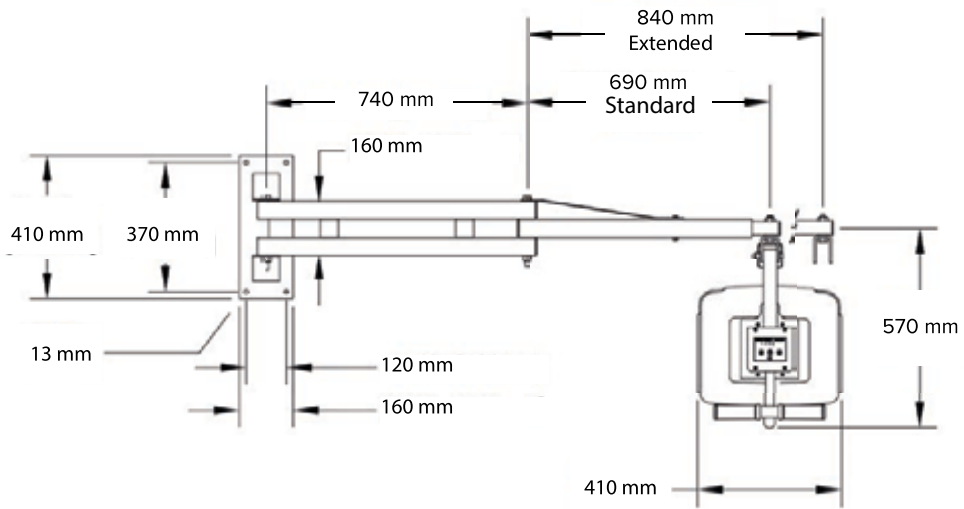

Shown with Optional Adjustable Height Wall Bracket

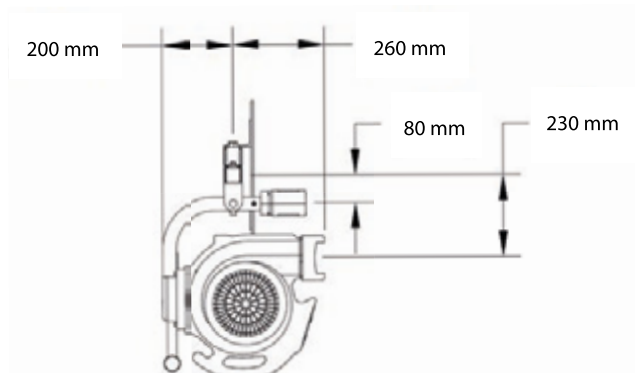

Ventilador Coolman 2800

Options

» Flex Neck Style LED Dock Light – Manual (mounted on blower)

- Power supply: 230V/50Hz 1Ph., separate (second) power supply required
- 18 Watt LED, Light colour 3500K, IEC 62471
- Photo-biological risk group 1 (low risk)
- Impact-resistant head (no glass)
- Dimmable with 4 different settings, lumen output:
 - Setting 1 (low): 487 lm
 - Setting 2 (moderate): 654 lm
 - Setting 3 (medium): 813 lm
 - Setting 4 (high): 956 lm
- Cable 6.1 m with safety plug (Schuko CEE 7/7, 250V/16A)

» Flex Neck Style LED Dock Light with Motion Sensoring (mounted on blower)

Same specifications as Flex Neck – Manual, but with:

- - Automatic dimming, lumen output:
 - Setting 1 (maximum): 956 lm
 - Setting 2 (automatic dimming): 813 lm (dims the light to 25% output, when no motion is detected)
 - Setting 3 (power save mode): 130 lm

» Adjustable Height Wall Bracket, allows 480 mm vertical movement for ideal positioning in the vehicle

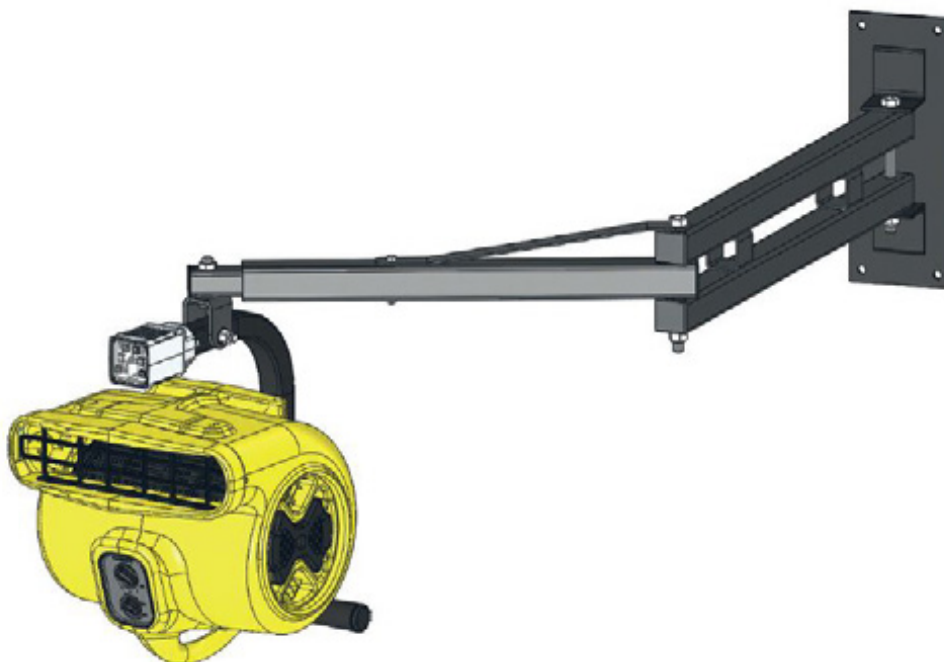

VINCA products

- Bridges crane and gantry cranes
- Jib cranes
- Hoists and winches
- Scissor Tables and scissor lifts
- Elevators/Lifts for loads (PLT)
- Dock levelers
- Moving Dock levelers (RMC)
- Coats Furniture
- Wheel-lok (Vehicle Immobilizer)
- Safety equipment for docks
- Vacuum lifters VACU-LIFT
- Industrial Manipulators
- Pallet Inverters /Tippers
- Levelers NIVELMATIC
- Tilters inclinador
- Skips
- Industrial fans
- Industrial flexible doors, high speed doors
- Cold storage doors
- Fire doors
- Safety gates DOK-GUARDIAN
- Festoon for mobile equipment
- Lifting appliances
- Industrial Radio Controls
- After Sales Service for above equipment

 ATEX classified equipment as option.



C/ Técnica, 39
 Pol. Ind. Torre Bovera
 08740 Sant Andreu de la Barca
 BARCELONA
www.vinca.es



BARCELONA

Tel 93 635 61 20
 Fax 93 635 61 30
info@vinca.es

MADRID

Tel: (+34) 616 91 69 82
madrid@vinca.es

VALENCIA

Tel: (+34) 647 817 537
valencia@vinca.es

GALICIA

Tel: (+34) 648 923 832
galicia@vinca.es